

Modular Cooking Range Line EVO900 6-Burner Gas Range 10kW on Large Gas Oven

ITEM # _____

MODEL # _____

NAME # _____

SIS # _____

AIA # _____



392016 (Z9GCGL6SLM)

6-burner (10 kW each) gas
range on large gas oven (12
kW)

Short Form Specification

Item No.

To be installed on stainless steel feet with height adjustment up to 50 mm. High efficiency flower flame burners with optimized combustion. Flame failure device as standard on burners to protect against accidental extinguishing. Oven chamber with 3 levels of runners to accommodate 2/1 GN shelves (2 steam pans). Ribbed, cast-iron oven base plate. Exterior panels of unit in stainless steel with Scotch Brite finish. Pan supports in heavy duty stainless steel. Extra strength work top in heavy duty 2 mm stainless steel. Right-angled side edges to allow flush-fitting junction between units.

Main Features

- Unit to be mounted on stainless steel feet with height adjustment up to 50 mm. Unit can be easily mounted on cantilever systems.
- The six 10 kW high efficiency burners are available in 100 mm diameter with power regulation from 2.2 kW to 10 kW.
- Gas appliance supplied for use with natural or LPG gas, conversion jets supplied as standard.
- Large sized pan support in cast iron (stainless steel as option) with long center fins to allow the use of the largest down to the smallest pans.
- Burners with optimized combustion.
- Flame failure device on each burner protects against gas leakage when accidental extinguishing of the flame occurs.
- Protected pilot light.
- Base compartment consists of a large gas heated standard oven with stainless steel burners and self stabilizing flame positioned beneath the base plate. Oven chamber to have 3 levels of runners to accommodate 2/1 GN shelves (2 steam pans) and ribbed cast iron base plate.
- Oven thermostat adjustable from 120 °C to 280 °C.
- 40 mm thick oven door for heat insulation.
- The special design of the control knob system guarantees against water infiltration.
- IPX5 water protection.

Construction

- All exterior panels in Stainless Steel with Scotch Brite finishing.
- AISI 304 stainless steel worktop, 2mm thick.
- Model has right-angled side edges to allow flush fitting joints between units, eliminating gaps and possible dirt traps.
- Pan supports in stainless steel.
- Unit is 900mm deep to give a larger working surface area.

APPROVAL: _____

Included Accessories

- 1 of Chrome grid for large oven PNC 206204

• Pressure regulator for gas units PNC 927225

Optional Accessories

- Junction sealing kit PNC 206086
- Draught diverter, 150 mm diameter PNC 206132
- Matching ring for flue condenser, 150 mm diameter PNC 206133
- 4 wheels, 2 swivelling with brake (EVO700/900). It is mandatory to install with base supports for feet/wheels. PNC 206135
- Flanged feet kit PNC 206136
- Frontal kicking strip for concrete installation, 1200 mm PNC 206151
- Side handrail for right/left hand PNC 206165
- Single burner smooth plate for direct cooking - fits frontal burners only PNC 206171
- Single burner ribbed plate for direct cooking - fits frontal burners only PNC 206172
- Frontal kicking strip, 1200 mm PNC 206178
- Frontal kicking strip, 1600 mm PNC 206179
- Pair of side kicking strips PNC 206180
- 2 panels for service duct (single installation) PNC 206181
- Large handrail (portioning shelf) 400 mm PNC 206185
- Frontal handrail 1200 mm PNC 206191
- Frontal handrail 1600 mm PNC 206192
- 2 panels for service duct (back to back installation) PNC 206202
- Chrome grid for large oven PNC 206204
- 4 feet for concrete installation (not for 900 line freestanding grill) PNC 206210
- Flue condenser for 1 module, 150 mm diameter PNC 206246
- Water column with swivel arm (water column extension not included) PNC 206289
- Water column extension PNC 206290
- Stainless steel grid for 2 burners PNC 206298
- Chimney upstand, 1200 mm PNC 206306
- 2 side covering panels, height 700 mm, depth 900 mm PNC 206335
- Wok pan support for open burners (EVO700/900) PNC 206363
- Base support for feet or wheels - 1200mm (EVO700/EVO900) PNC 206368
- Base support for feet or wheels - 1600mm (EVO700/900) PNC 206369
- Base support for feet or wheels - 2000mm (EVO700/900) PNC 206370
- Rear paneling - 1200mm (EVO700/900) PNC 206376
- Kit town gas nozzles (G150) for EVO900 gas ranges on gas oven PNC 206385
- Chimney grid net, 400mm PNC 206400

Modular Cooking Range Line
EVO900 6-Burner Gas Range 10kW on Large Gas Oven

The company reserves the right to make modifications to the products without prior notice. All information correct at time of printing.

Modular Cooking Range Line EVO900 6-Burner Gas Range 10kW on Large Gas Oven

Front

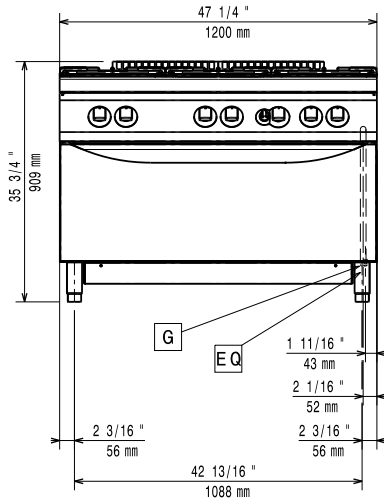

Side

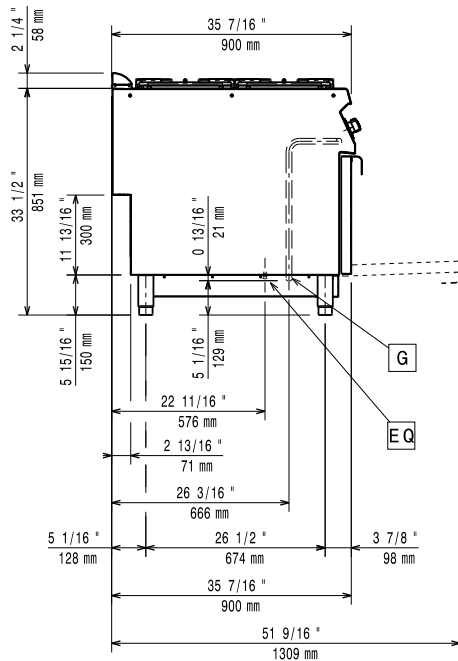

G = Gas connection

Top

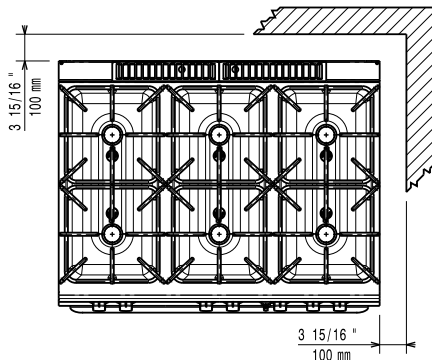

Gas

Gas Power:	72 kW
Standard gas delivery:	Natural Gas G20 (20mbar)
Gas Type Option:	LPG; Natural Gas
Gas Inlet:	1/2"

Key Information:

Oven working Temperature:	120 °C MIN; 280 °C MAX
Oven Cavity Dimensions (width):	1000 mm
Oven Cavity Dimensions (height):	380 mm
Oven Cavity Dimensions (depth):	700 mm
Net weight:	200 kg
Shipping weight:	198 kg
Shipping height:	1030 mm
Shipping width:	1020 mm
Shipping depth:	1300 mm
Shipping volume:	1.37 m ³
Front Burners Power:	ISO 9001; ISO 14001 - ISO 9001; ISO 14001 kW
Back Burners Power:	10 - 10 kW
Middle Burners Power:	10 - 0/10 - 0 kW
Certification group:	N9CG
Back Burners Dimension - mm	Ø 100 Ø 100
Front Burners Dimension - mm	Ø 100 Ø 100
Middle Burners Dimension - mm	Ø 100 Ø 100

If appliance is set up or next to or against temperature sensitive furniture or similar, a safety gap of approximately 150 mm should be maintained or some form of heat insulation fitted.